

## LDF Wall Cabinet

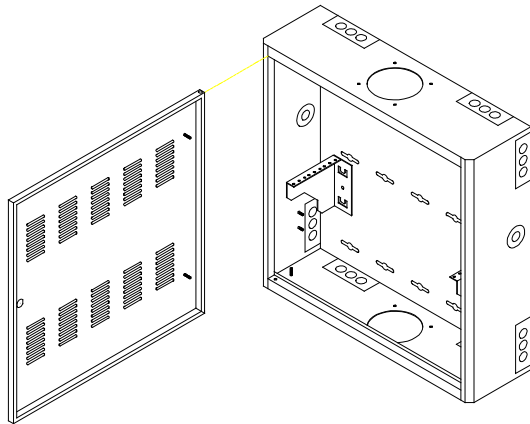

**SWE4449-CL Shown**

### Features

- Compact shallow design is ideal for small premise, school and office spaces
- Houses 19" multimedia cross connect panels and active network equipment in one cabinet
- 3u rack space for 19" hubs, UPS etc.
- Additional 3u rack space for 19" patch panels that hinges down for front access of terminations
- Optional rail placement provides for deeper equipment mounting (20" deep)
- Cable entrance points include 1/2" conduit knockouts and standard WM 4000 raceway entrance on all sides
- Secure environment with lock installed on front door
- Vented construction provides dissipation of 160 watts without fan
- Top & bottom of cabinet accepts optional fan kit
- Door is field reversible from left to right
- UL1950 compliant
- Powder coated finish
- Mounting provisions for duplex electrical box
- Multiple cable tie off points for cable management
- Multiple mounting holes in rear allow for variances in wall studs when mounting
- Ground studs for grounding door to base
- Dual Corbin 60 locks installed

### Specifications

- Constructed from 16 gauge carbon steel fully welded
- Mounting rails are provided with #10-32 hardware
- 100 lb. capacity
- Multiple mounting holes on 16" stud centers
- 3u vertical oriented rack space 11" deep & 3 passive rack units
- Colors available (Color code):
  - IBM White (W)
  - Black (BLK)

### Ordering Information

SWE4449-CL LDF Wall Cabinet 24"Wx7"Dx24"H with dual Corbin locks

### Optional Accessories

SWE705-RM Power Strip - 6 Outlet  
SWE706-53 Axial Fan with Cord  
SWETK Thermostat Kit for fan  
SWEPK 15A Power Kit w/ duplex box  
SWEFGK Fan filter and gasket kit

**To order:** Add color code to end of part number, e.g. SWE4449-CLBLK